

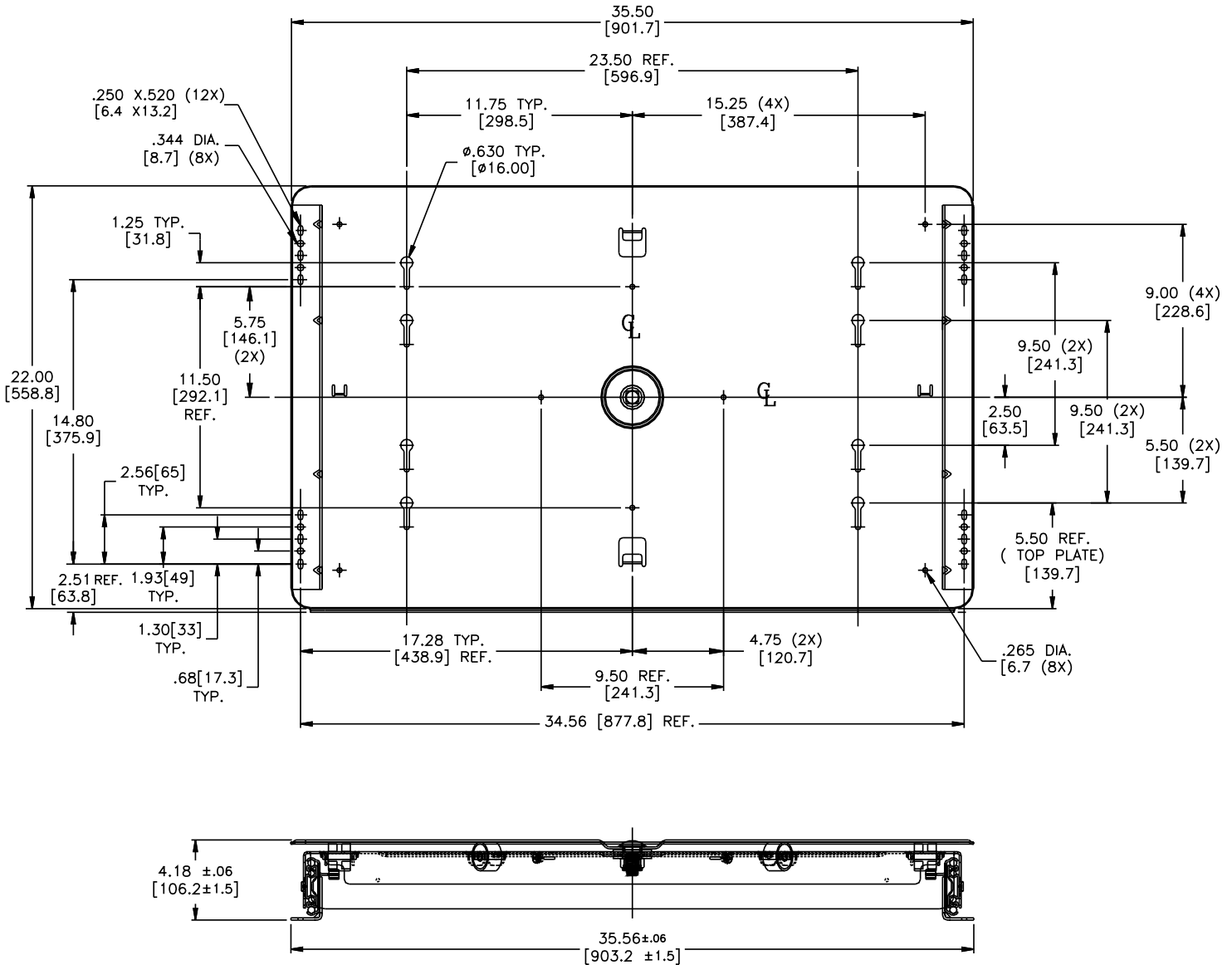

APPLICATIONS: For use in audio/visual equipment, home theaters and entertainment centers using flat panel or widescreen TV's up to 65" [914mm to 1651mm] in width. **This product is covered by U.S. and various foreign patents issued and/or pending.**

CB9320-258TV
Flat Panel/Widescreen
TV Swivel

325 lb.* [147.7 kg.] Capacity
 Optional Bracket Kit For
 Flat Panel Mounting



Finish	Slides: Black electroplate (CB) Swivel: Black powdercoat	Hardware	Mounting hardware included See "packaging" information on back page
Plate Dimensions	35.5" by 22.0" [901.7mm by 558.8mm]	Features	Slides: Detent closed, silenced open and closed Swivel: Center swivel position detent, 30° swivel
Height	4.18" [106.2mm]	Also	Optional brackets for flat panel TV mounting
Travel	22.00" [558.8mm] linear; 30° rotational		
Load	325 lbs.* [147.7 kg.]		
Mounting	Angle bracket		

* Load rating based on 10,000 cycles

PREPARATION

1. It is recommended that the cabinet base be a minimum of 3/4" thick. The cabinet base must be capable of supporting the intended load (see the CAUTION section on Page 4).
2. If a wood swivel platform is to be used, it should be at least 3/4" thick (plywood recommended), and should not overhang the front of the metal swivel plate.
3. The base frame of the television must sit flat on the metal or wood swivel platform. Casters or leveling glides should be removed from the television base prior to installation.
4. Position the swivel assembly on the cabinet base as far forward as possible. If a wood fascia will be attached to the bottom platform set the assembly back the thickness of the fascia.

INSTALLATION

1. With the assembly in its final location, mark the two large holes at the rear of each mounting bracket and two holes at the front of each mounting bracket with a pencil.
2. Remove the assembly to expose marks.
3. Drill the 4 rear mounting locations completely through the cabinet base with a 11/32" drill bit.
4. Drill 4 pilot holes at the front mounting locations with a 9/64" drill bit.
5. Replace the assembly. Slide the swivel platform forward slightly to expose the rearmost mounting holes. Install 4 each 5/16-18 X 1-1/4" hex-head machine bolts through the rear mounting holes as shown (Fig. 1).

Note: If the cabinet base is thicker than 3/4", longer machine bolts will be required (customer supplied).
6. Fully extend the swivel platform and install 4 each #14 X 3/4" slotted hex-head wood screws through the front pilot holes.

OPTIONAL FLAT PANEL BRACKETS

7. Install carriage bolts loosely through mounting flanges, as shown, with the bolt head hanging below the flange (Fig. 2).
8. Place the brackets over either the A or B set of keyhole slots in the swivel plate and pull forward so the square collar of the bolt fits into the adjustment slot (Fig. 3).

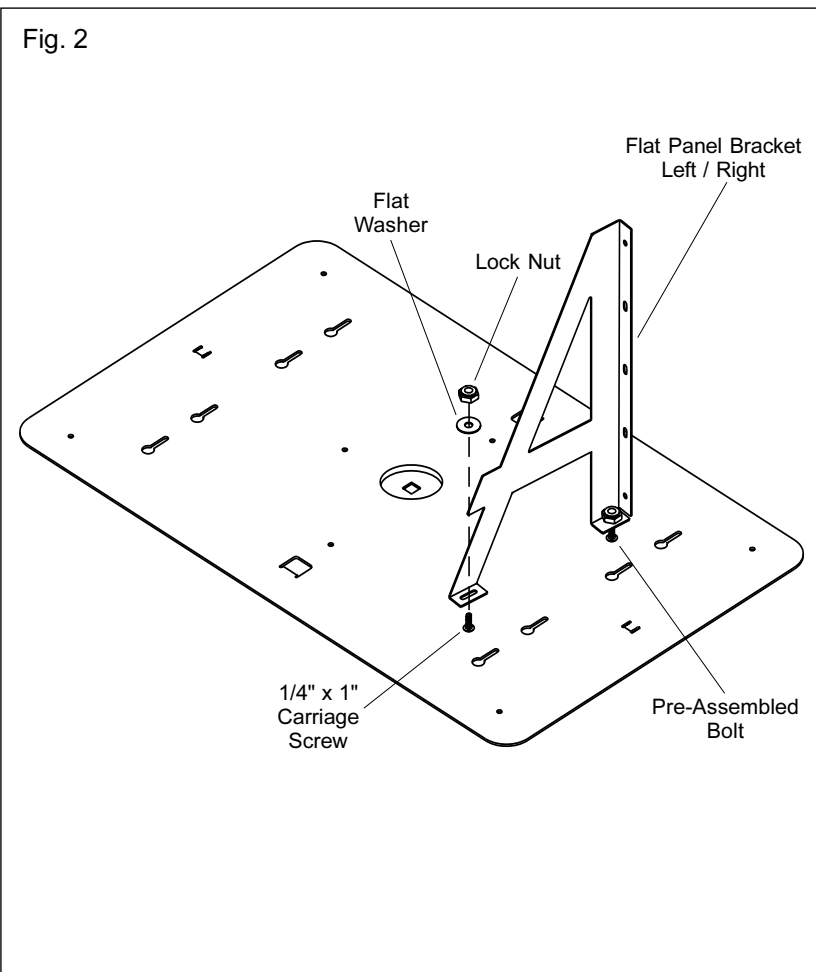
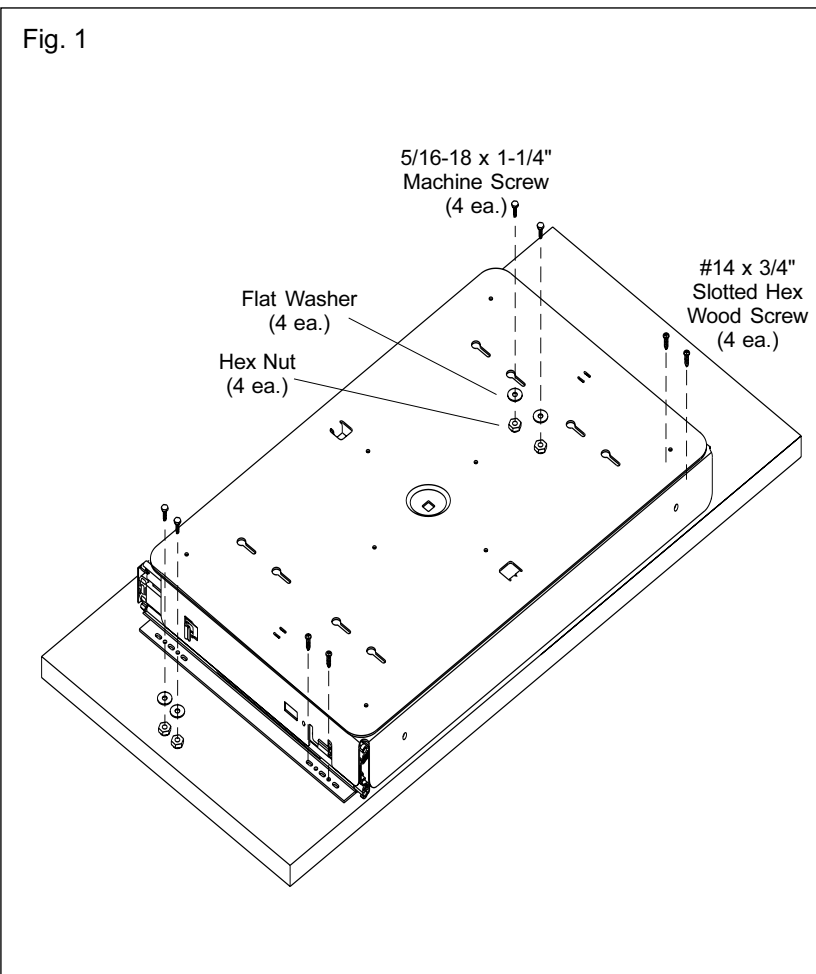

Note: Hole set A is recommended for flat panel TV's thinner than 3".

Hole set B is recommended for flat panel TV's thicker than 3".

9. Slide brackets front-to-back to desired position and tighten bolts securely.
10. Place a 3/4" plywood platform (customer supplied) directly on top of swivel platform against the brackets. Secure with 10 each #8 wood screws provided.

Note: The flat panel TV will attach to the plywood panel per the TV manufacturer's recommendations for wall mount applications.

OPTIONAL WOOD FASCIA

1. Cut the fascia 3-1/4" tall and no more than 36" wide.

Note: It is strongly recommended the fascia not exceed 36" wide. A wider fascia will be fragile and it will create a pinch point between itself and the swivel platform. If the open space beside the fascia is objectionable, small drawers can be added to the cabinet base to fill the space.

2. Place the fascia flush to the top of the metal base platform centered left-to-right. Ensure there is a gap of at least 1/4" between the metal swivel plate and the top of the fascia.
3. Secure from the back with 2 each #8 X 5/8" screws as shown (Fig. 4).

OPTIONAL WOOD SWIVEL PLATFORM

1. Three-quarter inch thick plywood is recommended for use as a swivel platform. The depth of the platform should be 22". The width should match the usable flat area of the TV frame.

Note: The frame of the TV must sit flat on the wood platform. Remove the leveling glides or casters from the TV or size the platform to fit between them.

2. Radius the corners of the platform as required to allow it to swivel in the extended position without contacting the surrounding cabinet.
3. Extend the metal swivel platform to expose the access holes on the underside.
4. Place the wood platform on the swivel centered left-to-right and flush to the front edge of the metal swivel platform (or flush to the front of the fascia if there is one).
5. Secure the wood platform with 8 each #8 X 5/8" screws as shown in Figure 5.

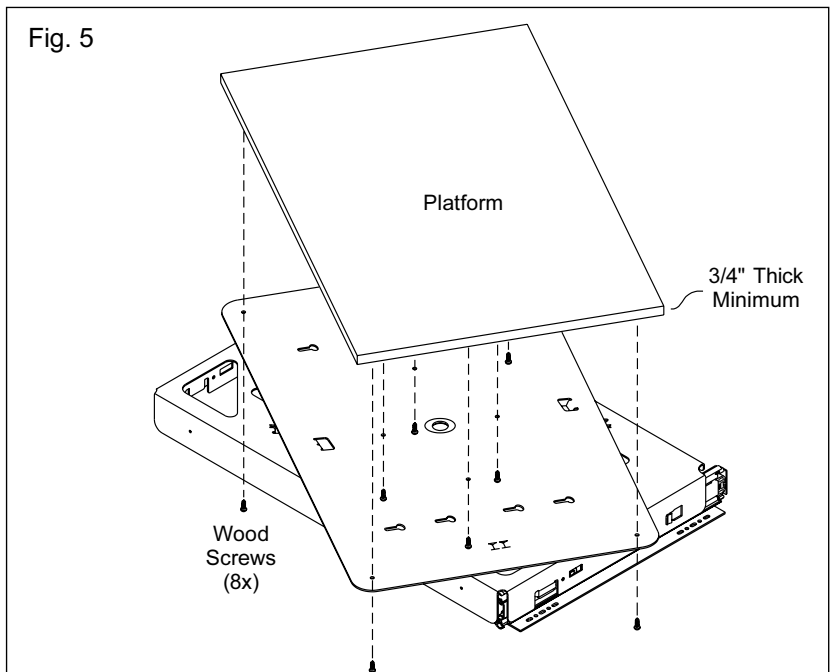
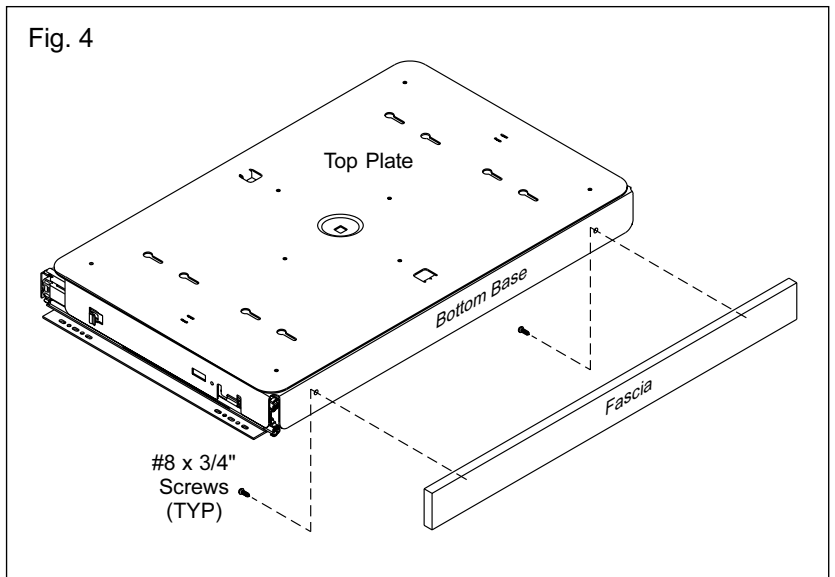
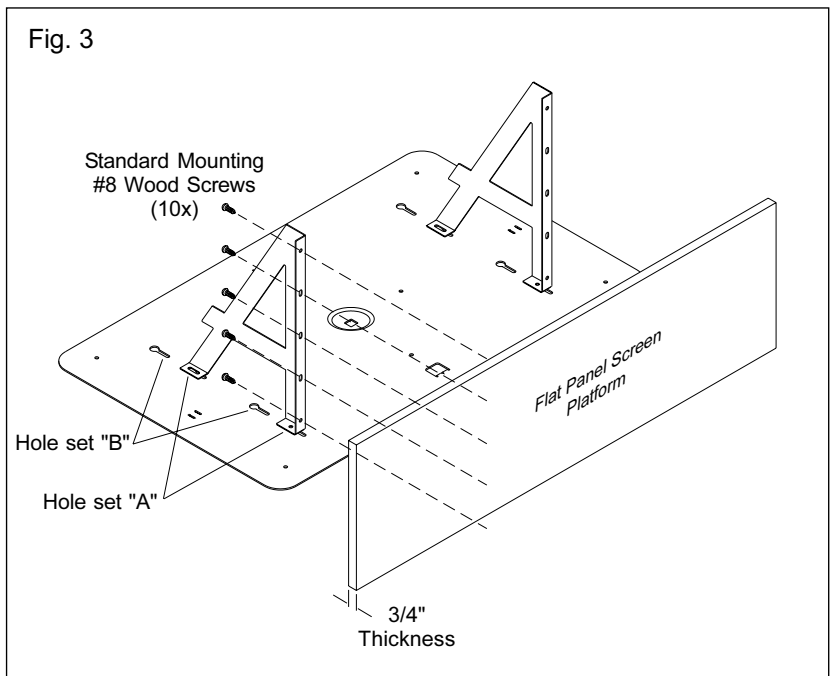

PLEASE READ THE FOLLOWING**CAUTION:**

- **This product is capable of carrying the stated loads when the structure into which it is mounted is designed to safely carry such loads.**
- The cabinetmaker should ensure the final structure is safe and stable when carrying the maximum intended load. ANSI/BIFMA X5.6 and U.L. 1950 provide standards for static and dynamic load, stability, and endurance testing.
- These and other applicable standards can be obtained from:

American National Standards Institute
25 West 43rd street, 4th Floor
New York, NY 10036
(212) 642-4900
www.ansi.org

Business and Institutional Furniture
Manufacturer's Association
2680 Horizon Drive, SE / Suite A-1
Grand Rapids, MI 49546-7500
(616) 285-3963
www.bifma.com

Underwriters Lab
1285 Walt Whitman Road
Melville, NY 11747-3081
(877) 854-3577
www.ul.com

In addition to the above, ensure the following:

1. The slide mounting surface to which the TV swivel assembly is bolted must be securely attached to the cabinet/structure walls.
2. Ensure the power and antenna cables are supported such that they are not stressed by extension and swivel action, nor tangled in the slide mechanism.
3. When fully loaded with the actual intended load, the entire structure must be stable when the sliding shelf is fully extended.
4. Before fully loading the pull-out swivel shelf, make sure the furniture is either counterbalanced or bolted to the floor or wall. This will ensure the furniture does not tip over when the shelf is fully loaded and extended.
5. The load on the sliding shelf must be restrained to prevent shifting or tipping as the shelf is extended. Velcro retaining straps are available through most major TV retailers.

Complete your order for Accuride model CB9320-258TV, flat panel/widescreen TV swivel, by specifying the following:

1 Each CB9320-258TV

Total Swivels Required _____

Flat Panel/Widescreen TV Swivel Part Number _____

Optional Flat Panel Mounting Bracket Kit

Complete your order for optional mounting brackets for flat panel TV's by specifying the following:

1 Each 4180-0519-XE

Total Bracket Kits Required _____

Bracket Kit Part Number _____

Each kit contains 2 mounting brackets and mounting screws packaged in a polybag. Order 1 bracket kit per TV swivel.

Packaging/Hardware Kit

One swivel assembly packaged in a special carton with slides attached to swivel plate. Hardware mounting kit provided and included with swivel assembly.

Hardware mounting kit, part number 4180-0522-XE, contains all hardware needed to mount one flat panel/widescreen TV swivel. Kit contains:

- 8 each #8 X 5/8" phillips round head wood screws
- 4 each #14 X 3/4" slotted hex-head wood screws
- 4 each #5/16-18 X 1-1/4" hex-head machine bolts
- 4 each #5/16-18 hex nuts
- 4 each #5/16-10 flat washers
- 4 each #5/16-18 lock washers
- 1 each Load rating sticker

Specifications

Slide members: Cold rolled steel
Ball retainers: High strength plastic
Ball bearings: Carburized steel

Note: Specifications, materials, prices, terms, and delivery are subject to change without notice.

Accuride

ACCURIDE INTERNATIONAL INC.

12311 Shoemaker Avenue
Santa Fe Springs, CA 90670
TEL (562) 903-0200
FAX (562) 903-0208
www accuride.com

Manufacturing, Engineering, and Sales
United States • Germany • Japan • Mexico • United Kingdom